



PASQUILL

SAINT-GOBAIN

» CULLEN «

GANG-NAIL

TOOLMATIC®

Paslode

Brands for the offsite industry

Gable Restraint System Technical Guide

UP TO 5 STOREYS



**CONSTRUCTION
PRODUCTS**

Gable Restraint System

ITW Construction Products' Cullen brand of timber engineering connectors has been synonymous with innovation and quality for over forty years. In collaboration with national housebuilders, the Trussed Rafter Association and industry partners, ITW's technical experts have created an innovative system featuring the Cullen Gable Restraint Bracket for a complete solution to connect timber gables to masonry walls.

The details have been developed to safely transfer lateral wind load

on the masonry and timber gable ends into the braced roof diaphragm. This provides a verified connection between timber gable panels to masonry walls. The details give an option to have a continuous wall plate or a stepped wallplate with the gable wall plate being raised to suit the bottom chord depth of the truss. Either of the details meets the minimum requirement of Building Regulations 2010 approved document A, Scottish Building regulations domestic, NHBC Standards for houses

of five storeys or less in England and Wales and four storeys or less in Scotland. Both details are accepted by NHBC.

This NHBC accepted "whole system" solution incorporating the Cullen Gable Restraint Bracket and restraint straps including Paslode nail fixings with all centres, spacings and connections already calculated means that whenever our detail is followed the system is underwritten by ITW Construction Products.

Gable Restraint Bracket & Application

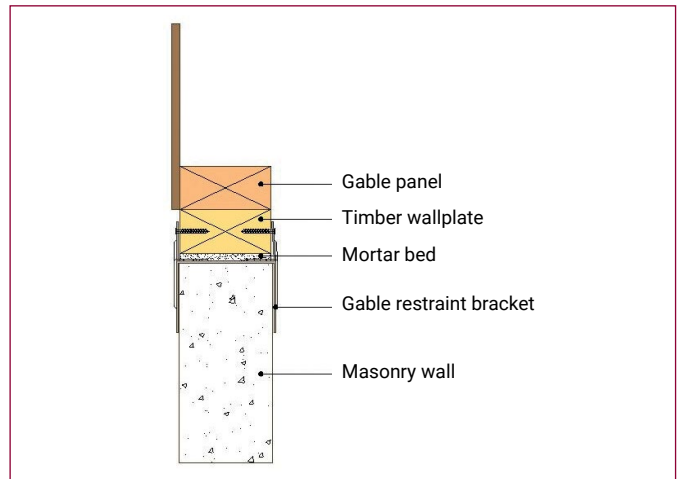
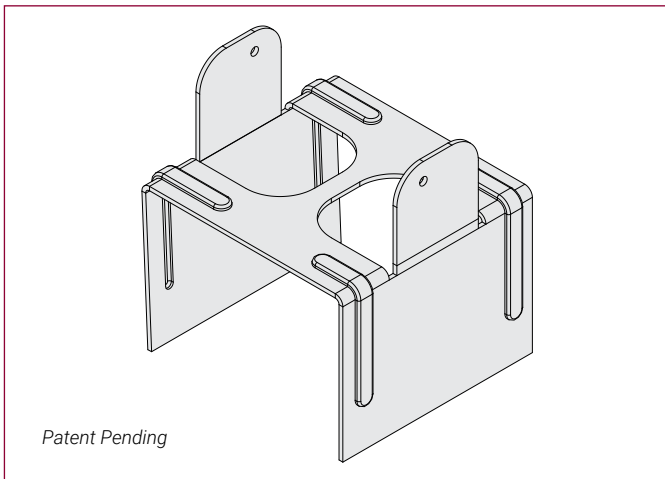

Gable Restraint Bracket Installation

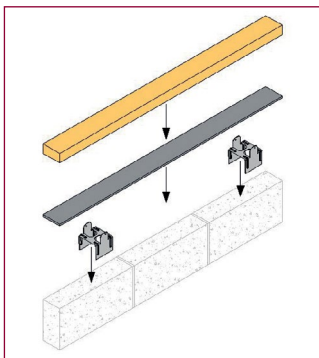

Components:

- Wallplate
- Mortar
- Gable Restraint Brackets
- Wall

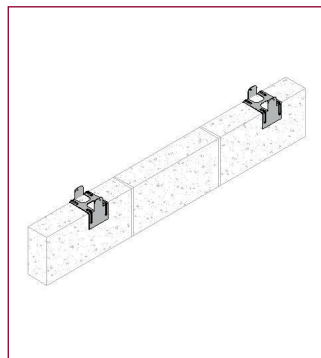

Gable restraint brackets placed on wall at 1200mm* maximum centres (no fixings required).

*for buildings up to 3 storey England & Wales and 2 storey Scotland

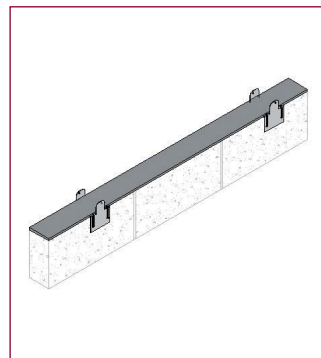

10mm maximum mortar bed on wall prior to wallplate being fixed.

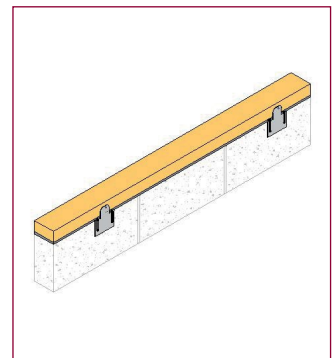

38-75mm wallplate bedded on mortar and fixed to gable restraint brackets with 3.5x40mm wood screws (2 no. per bracket).

Class 1 Buildings / houses of single occupancy **three storeys** or less England & Wales and **two storeys** or less Scotland

Timber Gable to Masonry fixing detail to cold roofs – continuous wallplate

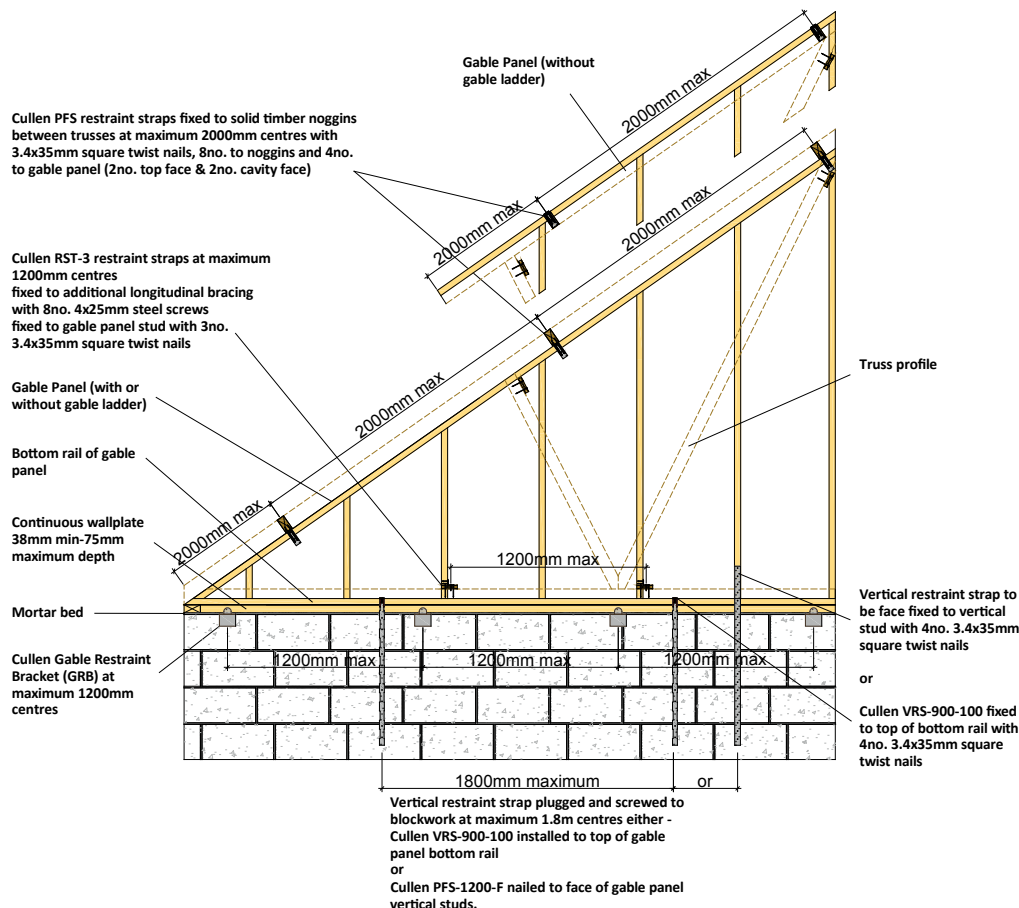
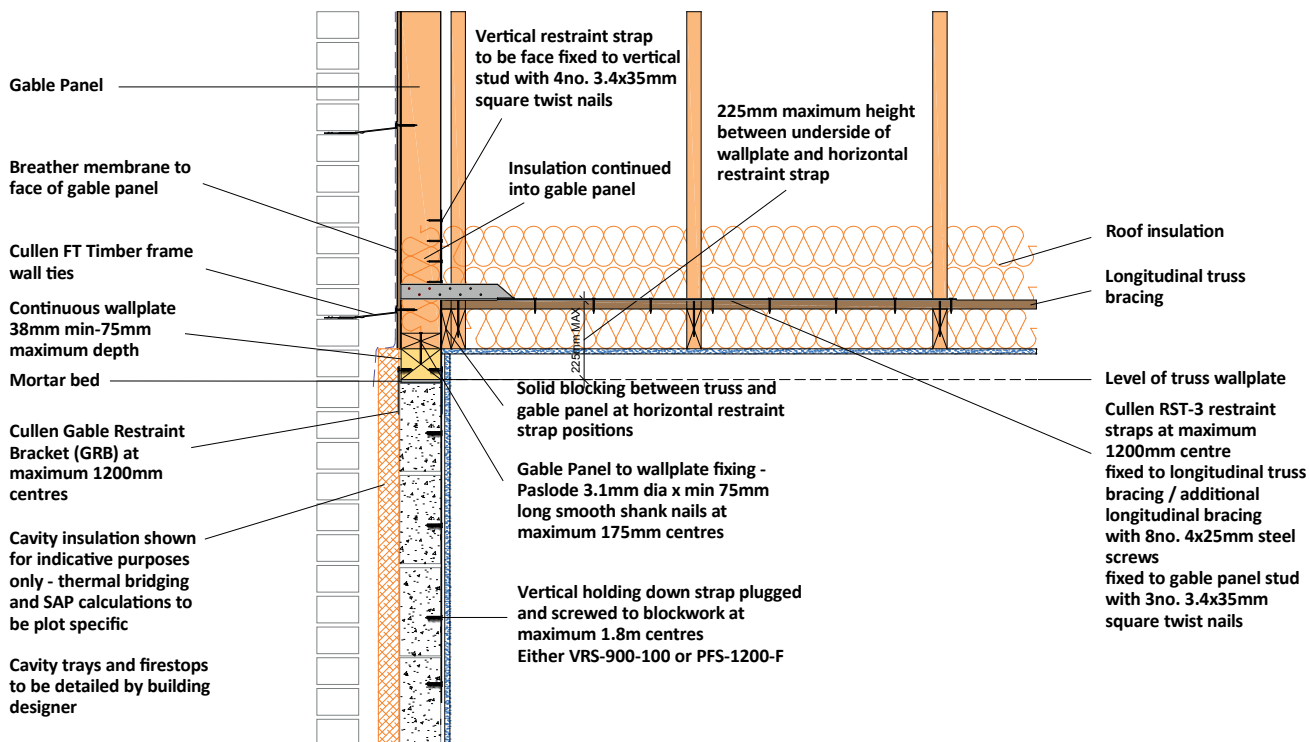

Gable Restraint System

Class 1 Buildings / houses of single occupancy **three storeys** or less England & Wales and **two storeys** or less Scotland

Timber Gable to Masonry fixing detail to cold roofs – raised gable wallplate

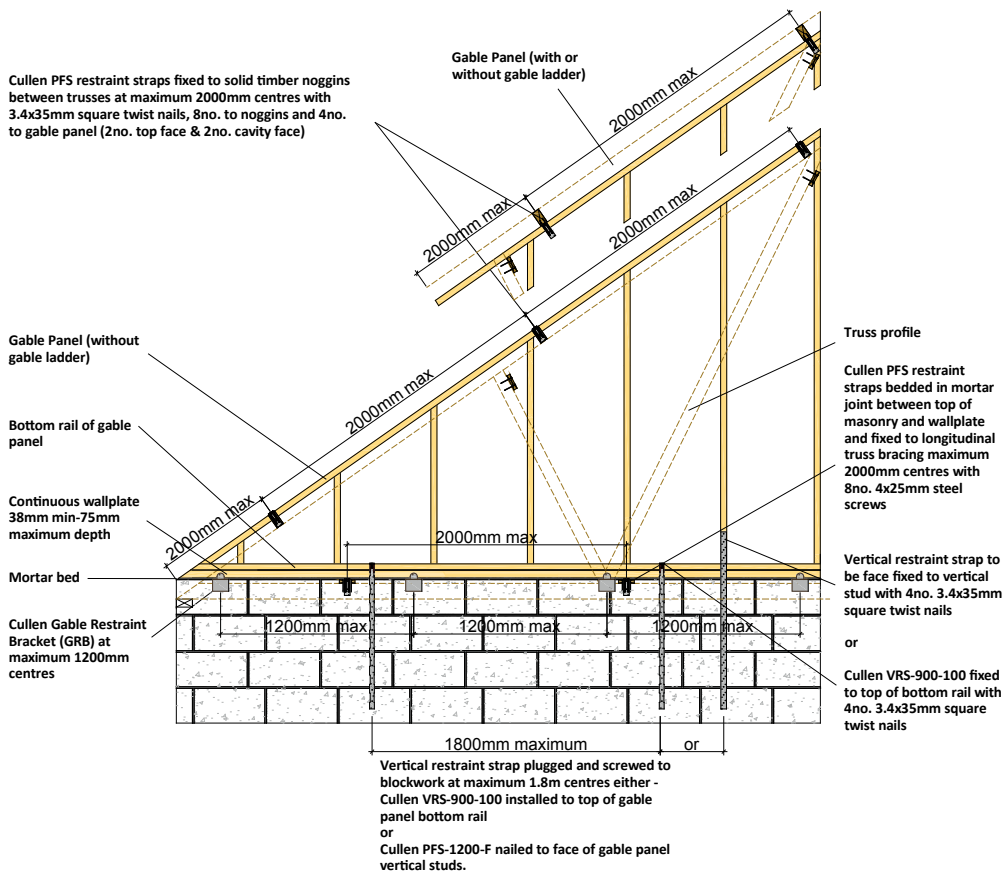
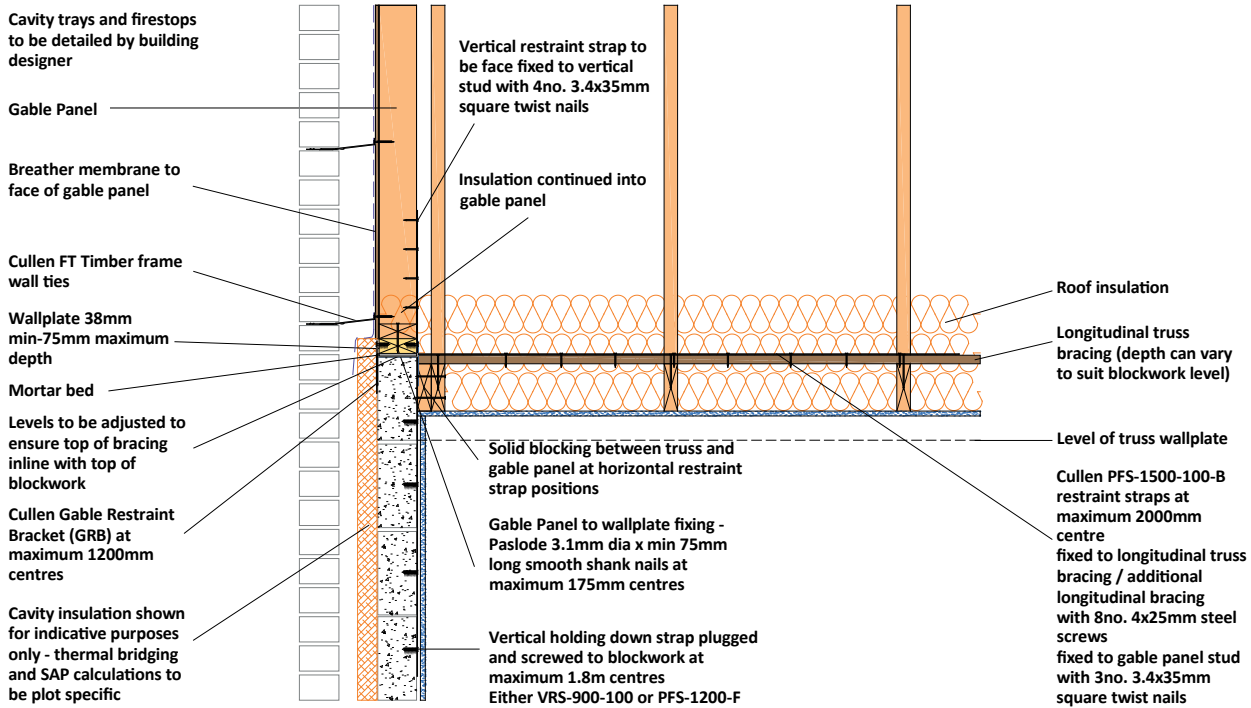

Class 2a Buildings / houses of single occupancy **five storeys** or less England & Wales and **four storeys** or less Scotland

Timber Gable to Masonry fixing detail to cold roofs – continuous wallplate

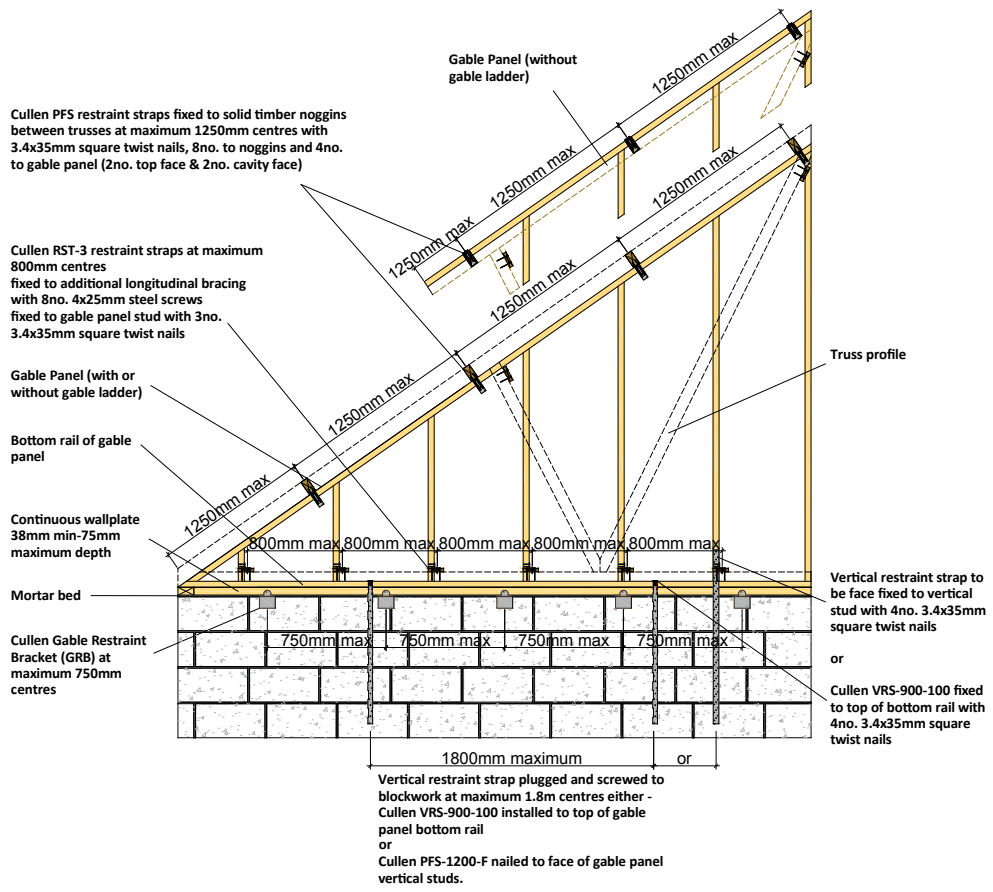
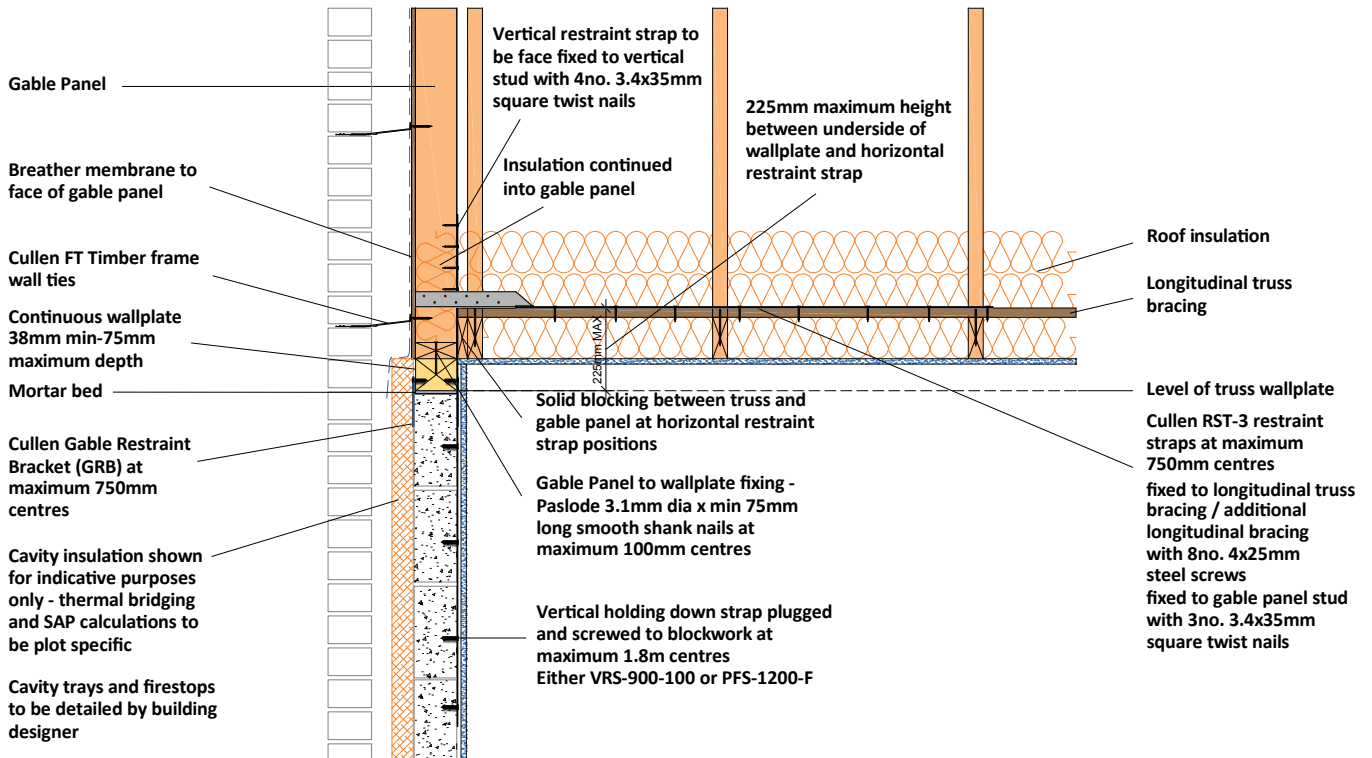

Gable Restraint System

Class 2a Buildings / houses of single occupancy **five storeys** or less England & Wales and **four storeys** or less Scotland

Timber Gable to Masonry fixing detail to cold roofs – raised gable wallplate

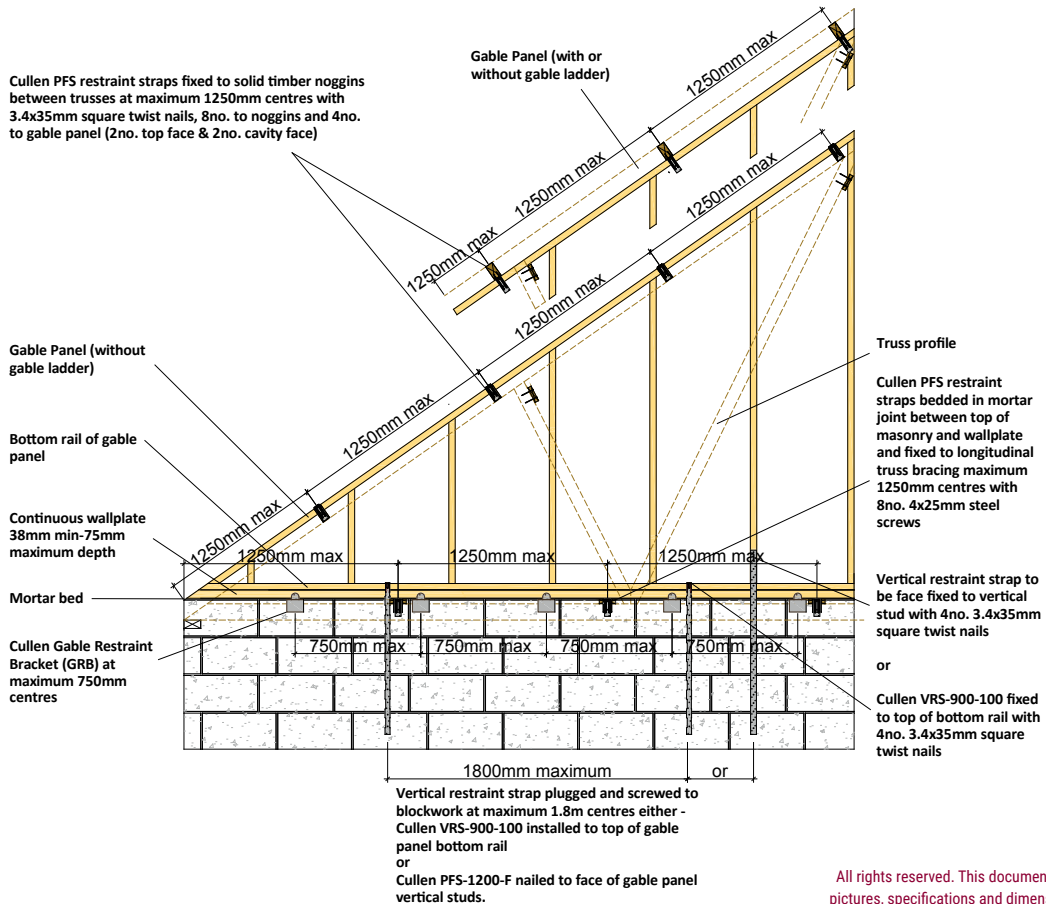
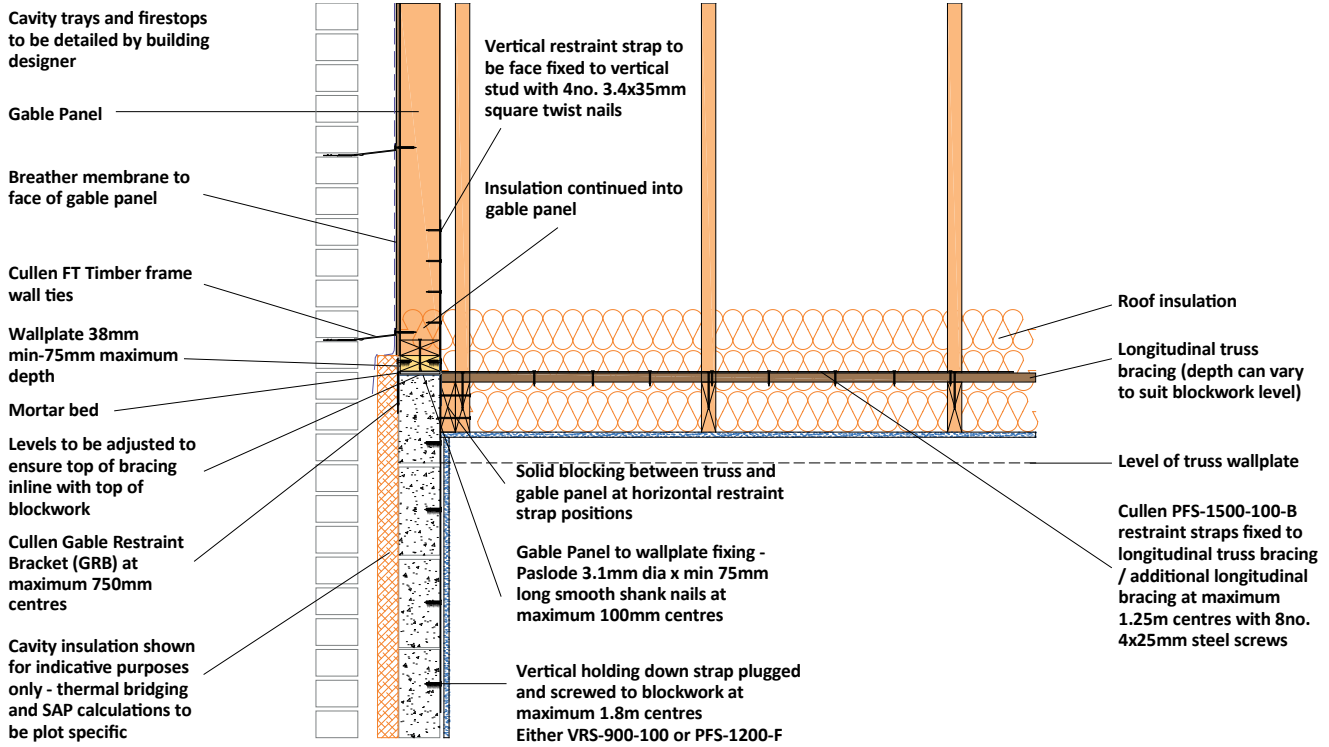

Copyright © 2023 ITW

All rights reserved. This document (including text, material, pictures, specifications and dimensions contained in it) may not be reproduced, transmitted or distributed or otherwise used in any way or by any means, except with the prior express permission of ITW Construction Products Offsite.



SAINT-GOBAIN

Pasquill Distribution Network

BODMIN

Cooksland Road
Bodmin PL31 2RH
T: 01208 75777
Email: bodmin@pasquill.co.uk

BURY ST EDMUNDS

Integ House, Woodlands Business Park
Rougham Ind. Estate
Bury St Edmunds IP30 9DN
T: 01359 271475
Email: burystedmunds@pasquill.co.uk

CHORLEY

Wigan Lane, Duxbury
Chorley, Lancashire PR7 4BU
T: 01257 264851
Email: chorley@pasquill.co.uk

COVENTRY

Orchard Court 3, Binley Business Park
Coventry CV3 2TQ
T: 02476 438691
Email: coventry@pasquill.co.uk

DUNDEE

Design Centre
1 Valentine Court,
Dundee DD2 3QB
T: 01382 768 660
Email: dundee@pasquill.co.uk

HUDDERSFIELD

Access via Gibbs & Dandy
Manor Mills, Kings Mill Lane
Huddersfield HD1 3AW
T: 01484 544428
Email: huddersfield@pasquill.co.uk

INVERNESS

3 Dalcross Industrial Estate
Inverness IV2 7XB
T: 01667 462102
Email: inverness@pasquill.co.uk

LEEDS

Jawbone Industrial Estate, Wood Lane
Rothwell, Leeds LS26 0RS
T: 01133 934977
Email: leeds@pasquill.co.uk

OLDBURY

Unit 3 Oldbury Park
Popes Lane, Oldbury
Birmingham B69 4RG
T: 01527 879515
Email: oldbury@pasquill.co.uk

REDHILL

Salfords Industrial Estate
Salbrook Road, Salfords
Redhill RH1 5GJ
T: 01293 776680
Email: redhill@pasquill.co.uk

SOUTH SHIELDS

South Shields Business Works
Henry Robson Way
South Shields NE33 1RF
T: 0191 4274791
Email: southshields@pasquill.co.uk

STONEY STANTON

Station Road
Stoney Stanton
Leicestershire LE9 4NA
T: 01455 270100
Email: Leicester@pasquill.co.uk

UDDINGSTON

9 Grays Road
Green Elms Trading Estate
Uddingston G71 6ET
T: 01698 801560
Email: uddingston@pasquill.co.uk

WATTON

Design Centre
Unit 5, Crossroads Business Park,
Saham Road, Ovington, Thetford,
Norfolk IP25 6RR
T: 01953 885219
Email: watton@pasquill.co.uk



Customer Services:

ITW Construction Products
1 Wheatstone Place
Southfield Industrial Estate
Glenrothes
Fife
KY6 2SW

t : +44 (0)1592 771132
e : orders@itwcp.com

Technical Support:

t : +44(0)1592 771132
e : technical@itwcp.com



CONSTRUCTION PRODUCTS

© ITW Construction Products

No part of this publication may be reproduced
without prior permission from ITWCP.

A division of ITW Limited

Registered in England and Wales No. 00559693

www.itwcp-offsite.co.uk

